



BTM-0127



Φ9.0 x 4.0(h) mm

ORDERING CODE: **BTM - 0127**

① ② ③ ④

① Magnetic Buzzer

② Series Number

③ Rated Voltage

④ Rated Frequency

NO	SPECIFICATION	DATA
1	Rated Voltage (V)	1.5
2	Operating Voltage (V)	1 ~ 2
3	Coil Resistance (Ω)	5.5±1
4	Resonant Frequency (Hz)	2731±300
5	*Sound Output at 10cm (dB)	Min 85
6	*Current Consumption (mA)	Max 80
7	Operating Temperature (°C)	-25 ~ +70
8	Storage Temperature (°C)	-30 ~ +80
9	Weight (g)	0.8g
10	Housing Material	PPO
11	RoHS	YES
12	Packing Quantity	1,000pcs/1box

*Applying rated voltage (Resonant frequency, 1/2 duty, Square wave)

DIENSIONS (unit : mm)

Tolerance: ±0.5mm Except Specified

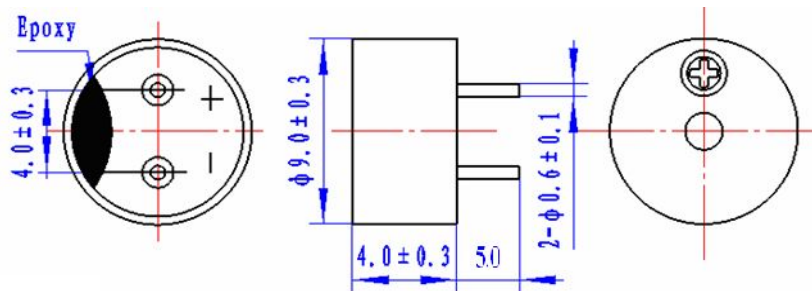



BTM-0327



Φ9.0 x 4.0(h) mm

ORDERING CODE: **B T M - 0 3 2 7**

① ② ③ ④

① **Magnetic Buzzer**

② **Series Number**

③ **Rated Voltage**

④ **Rated Frequency**

NO	SPECIFICATION	DATA
1	Rated Voltage (V)	3
2	Operating Voltage (V)	2~4
3	Coil Resistance (Ω)	16±3
4	Resonant Frequency (Hz)	2731±300
5	*Sound Output at 10cm (dB)	Min 85
6	*Current Consumption (mA)	Max 80
7	Operating Temperature (°C)	-25 ~ +70
8	Storage Temperature (°C)	-30 ~ +80
9	Weight (g)	0.8g
10	Housing Material	PPO
11	RoHS	YES
12	Packing Quantity	1,000pcs/1box

*Applying rated voltage (Resonant frequency, 1/2 duty, Square wave)

DIENSIONS (unit : mm)

Tolerance: ±0.5mm Except Specified

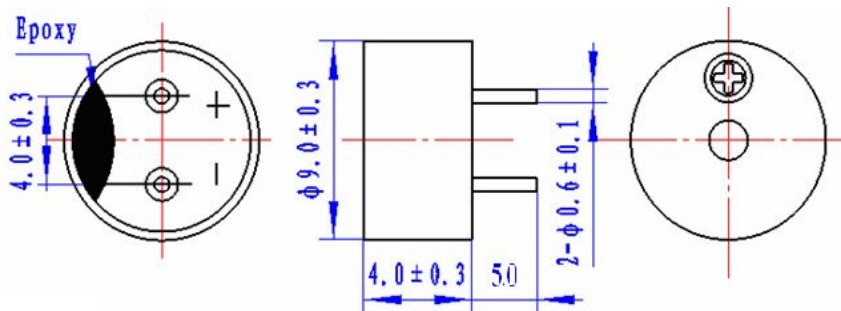



BTM-0527



Φ9.0 x 4.0(h) mm

ORDERING CODE: **B T M - 0 5 2 7**

① ② ③ ④

① Magnetic Buzzer

② Series Number

③ Rated Voltage

④ Rated Frequency

NO	SPECIFICATION	DATA
1	Rated Voltage (V)	5
2	Operating Voltage (V)	4 ~ 6
3	Coil Resistance (Ω)	30±3
4	Resonant Frequency (Hz)	2731±300
5	*Sound Output at 10cm (dB)	Min 85
6	*Current Consumption (mA)	Max 80
7	Operating Temperature (°C)	-25 ~ +70
8	Storage Temperature (°C)	-30 ~ +80
9	Weight (g)	0.8g
10	Housing Material	PPO
11	RoHS	YES
12	Packing Quantity	1,000pcs/1box

*Applying rated voltage (Resonant frequency, 1/2 duty, Square wave)

DIENSIONS (unit : mm)

Tolerance: ±0.5mm Except Specified

