

MODEL	"L"
1101H	4.3mm
1101HA	5.0mm

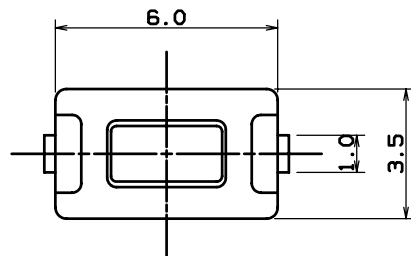

CIRCUIT DIAGRAM

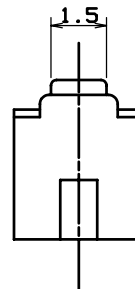
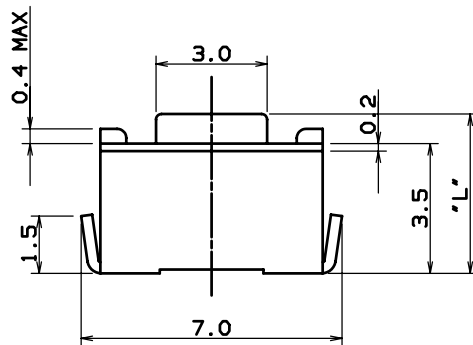
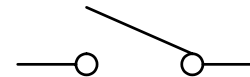

NOTE

1. OPERATING FORCE : 180 ± 50 gf
2. TRAVEL : 0.25 +0.2/-0.1 mm
3. CONTACT RESISTANCE : 100mΩ Max
4. GENERAL TOLERANCE : ± 0.3

P.C.B. LAND DIMENSION

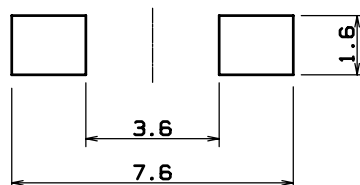

NO	PART NAME	Q'TY	MATERIAL	REMARKS
1	CASE	1	ARLEN	
2	STEM	1	ARLEN	
3	COVER	1	SUS304-H	
4	TERMINAL	1	C2680R-EH	Ag PLATE
5	C/PLATE	1	SUS301-EH	Ag 0.5μ

No.	PART NAME	Q'TY	MATERIAL	SIZE	TREAT.	REMARKS
△			3RD ANGLE PROJECTION	UNIT m/m	SCALE 1	MODEL MT 1101H-2
△			APPROVED	CHECKED	DESIGNED	DWG. NAME ASS'Y DIAGRAM
△						DWG. NO.
NO.	DATE	NOTE	SIGN			