

CIRCUIT DIAGRAM

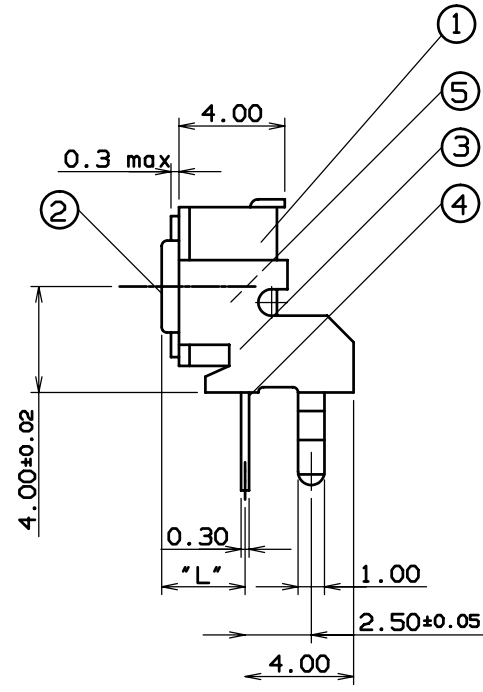

NO	PART NAME	Q'TY	MATERIAL	REMARKS
①	CASE	1	NYLON66 G30	BLACK
②	STEM	1	NYLON66 G30	
③	BRACKET	1	SPTe	
④	TERMINAL	1	C2680R-EH	Ag 0.5μ
⑤	C/PLATE	1	C5210R-EH Ag clad 0.5μ	

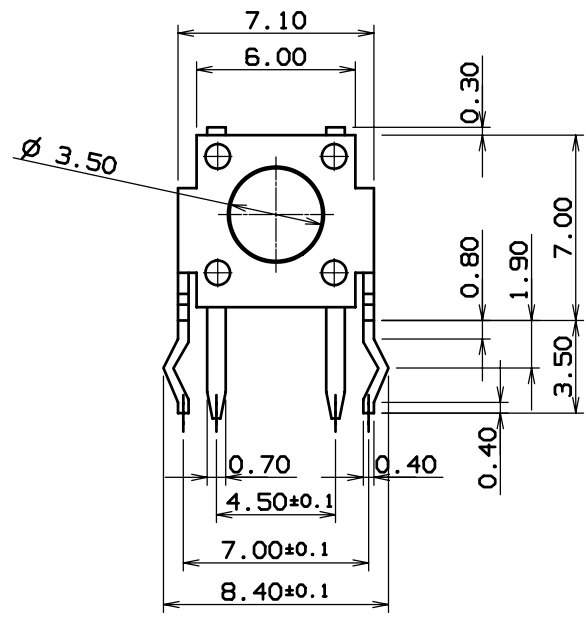

MODEL	"L"	COLOR
MT1102H	3.15	BLACK
MT1102HA	3.85	BLACK
MT1102HB	8.35	BLACK
MT1102HC	6.85	WHITE
MT1102HD	11.85	BLACK
MT1102HE	6.15	IVORY
MT1102HF	5.85	BLACK

MODEL	O/F FORCE	COLOR
MT1102H	100gf	BROWN
MT1102H-1	130gf	GRAY
MT1102H-2	160gf	
MT1102H-3	250gf	RED

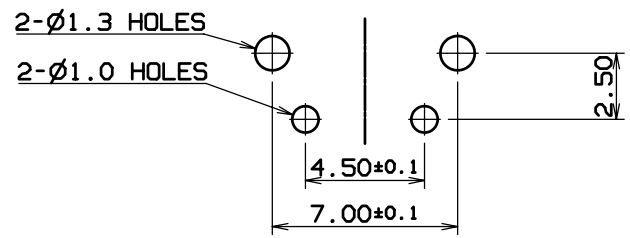

P.C.B DIMENSION

NOTE

- 1. OPERATING FORCE :
- 2. TRAVEL : 0.25 +0.2/-0.1 mm
- 3. CONTACT RESISTANCE : 100ma Max
- 4. GENERAL TOLERANCE : ±0.3

No.	PART NAME	Q'TY	MATERIAL	SIZE	TREAT.	REMARKS
30° ANGLE PROJECTION	UNIT	SCALE	MODEL			
APPROVED	CHECKED	DESIGNED	MT 1102H SERIES			
			DWG. NAME			
			ASS'Y DIAGRAM			
			DWG. NO.			
NO.	DATE	NOTE	SIGN			